

# Full Range Multiphase Flow Meter



The Haimo [full range multiphase flow meter](#) is a combination of a gas / liquid two phase flow meter and a three phase water cut meter.

## Introduction

### Design Philosophy and Principle of Operation

The Haimo **full range multiphase flow meter** is a combination of a gas / liquid two phase flow meter and a three phase water cut meter.

Measurement of the gas and liquid flow rates is carried out in the gas / liquid two phase meter that consists of a venturi and a single gamma meter. The Water Liquid Ratio (WLR) is measured with the dual gamma meter which is located downstream of the flow conditioner.

The phase fractions are derived from these two independent measurements and net oil flow rate is finally calculated using the gross liquid flow rate and water cut measurement.

In general, the Water Liquid Ratio (WLR) measurement accuracy deteriorates with slugging as well as very high Gas Volume Fraction (GVF), therefore in order to measure WLR accurately Haimo has introduced a flow conditioner upstream of the dual energy gamma water cut meter to condition the multiphase flow by mitigating slugs and reducing the higher GVF level. This helps achieve the water cut measurement error within  $\pm 2\%$  absolute for the full range of stated GVF in the meter's operating envelope.

## Measurement principle

Total flow rate of the multiphase stream is measured by the venturi flow meter. Gamma ray technology is used to measure phase fractions, GVF and WLR respectively. A patented inline sampler helps to decrease gas fraction in the multiphase flow and enables accurate WLR measurement even at extremely high GVF. The multivariable transmitter (MVT) measures pressure, temperature and differential pressure. The pulses from the gamma meters are processed by a new design of high-frequency transmitter. A Data Acquisition Unit (DAU) performs all calculations and converts flow measurements from line to standard condition.

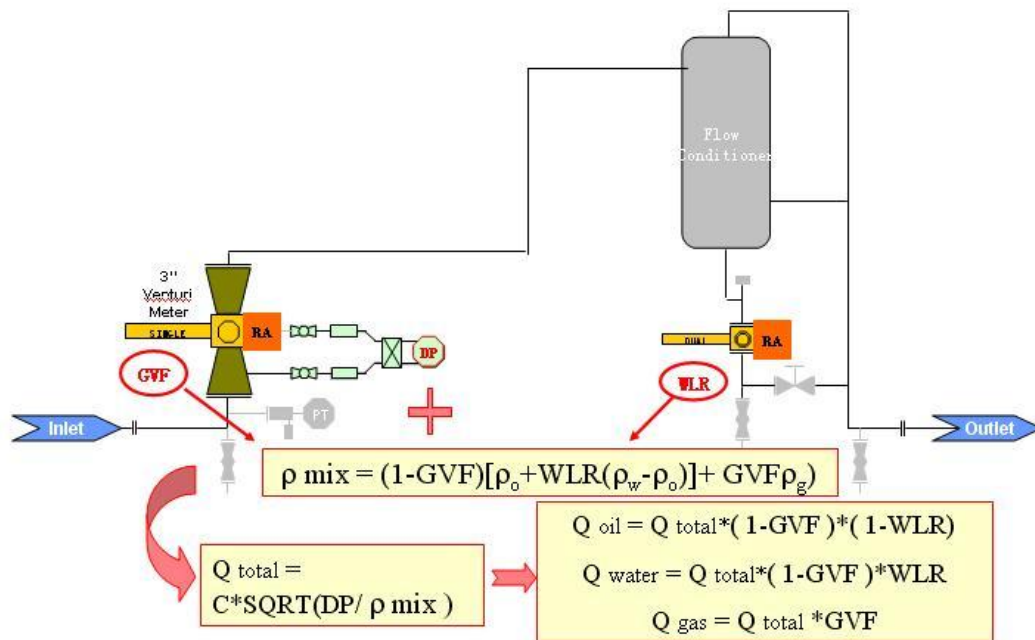

## Performance

### Meter Specifications:

Meter size (inch)	1.5-6
WLR (Water Liquid Ratio,%)	0-100
GVF (Gas Volume Fraction,%)	0-100
Equipment Materials	CS,SS,DSS,Inconel,Alloy,
Electrical Certification	EEx dII B T4/T6
Ingress Protection	(IP) IP 65/66

**Measurements Uncertainty (Confidence Level=95%):**

GVF Range	Measurements	Uncertainty P<20Bar	Uncertainty P $\geq$ 20Bar
0-95%	Liquid flow (rel)	5.0%	5.0%
	Gas flow (rel)	7.0%	5.0%
	Water cut (abs)	2.0%	2.0%
95-100%	Hydrocarbon flow (rel)	5-10%	3.0%
	Gas flow (rel)	7.0%	2.0%
	Water cut (abs)	2.5%	2.5%

## Features

- Best in class for water cut measurement – a key factor in resulting net oil accuracy
- Flow regime independent
- Wide operating range with low pressure drop
- Non-intrusive and in-line measurement techniques
- Field oriented design, small footprint and cost effective mobilization
- Compact, robust and easy to install meter –ideal for remote locations
- High frequency data acquisition, provides real time well data at line and standard conditions

Full Range Multiphase Flow Meter (MPFM)

<http://www.haimotech.com/Products-and-Services/MPFM/Multiphase-Flow-Meter.html>

E-mail: [sales@haimotech.com](mailto:sales@haimotech.com)